

TRANSPARENT LEVEL GAUGES

Type T 85



T 85-DA

T 85-DVK 2

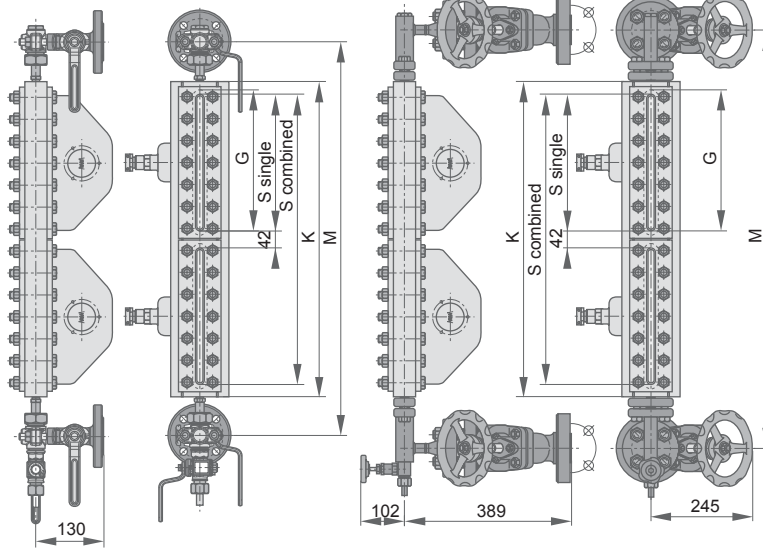

T 85

PN 160

85 bar

298 °C

Saturated Steam

Nominal pressure:

PN 160, 85 bar

298 °C saturated steam

with gauge cock DA

with gauge valve DVK 2

Construction to KLINGER

material code FS/H

Gauge glass:

Klinger Transparent glass B

Material Borosilicate

Mica shield B

Illuminator IP 65

Connection

gauge body – gauge cock

Rotatable (360°)

Gauge cock DA: Connecting piece and connecting nut. Seal between gauge and connecting piece joint ring.

Gauge valve DVK 2: Connecting piece with flanges. Seal between gauge and connecting piece joint ring

Connection construction

End connection with gauge cocks DA and gauge valves DVK 2 (see illustration). Safety ball in the upper and lower shut-off fitting.

Vessel connection with flanges or male threads to all recognized standards.

Weight: Gauges cocks with DN 25 flanges approx. 9,5 kg. Gauge valve set approx. 44 kg.

Torque for body bolts 100 Nm, cold 92 Nm under working conditions.

For gauge body and gauge cock part lists, dimensions of glasses and material specifications see pages 12 and 39.

Suggested order specification

Transparent level gauge PN 160

KLINGER material code FS/H

Gauge glass Borosilicate

thermally prestressed

Connection gauge body – shut-off fitting

rotatable

Shut-off fittings gauge cocks and gauge valves with safety balls

Ordering example:

T 85-DVK 2, 4 x IX, FS/H

DN 25 / PN 160

Overall and connection dimensions (mm)

Gauge size	Centre-to-centre distance M min	Body length K	Sight length S	Glass length G	Approx. weight of gauge (kg)
II	313	180	115	140	16,10
III	338	205	140	165	17,50
IV	363	230	165	190	18,60
V	393	260	195	220	20,30
VI	423	290	225	250	22,20
VII	453	320	255	280	23,50
VIII	493	360	295	320	26,10
IX	513	380	315	340	27,70
2 x IV	570	437	372	190	24,70
2 x V	630	497	432	220	27,40
2 x VI	690	557	492	250	32,00
2 x VII	750	617	552	280	35,70
2 x VIII	830	697	632	320	40,60
2 x IX	870	737	672	340	43,10
3 x VI	957	824	759	250	48,10
3 x VII	1047	914	849	280	53,60
3 x VIII	1167	1034	969	320	60,60
3 x IX	1227	1094	1029	340	64,70
4 x VII	1344	1211	1146	280	71,50
4 x VIII	1504	1371	1306	320	81,30
4 x IX	1584	1451	1386	340	86,30
5 x VII	1641	1508	1443	280	89,40
5 x VIII	1841	1708	1643	320	101,70
5 x IX	1941	1808	1743	340	107,80
6 x VIII	2178	2045	1980	320	122,10
6 x IX	2298	2165	2100	340	129,40
7 x VIII	2515	2382	2317	320	142,50
7 x IX	2655	2522	2457	340	151,00
8 x IX	3012	2879	2814	340	172,60

The maximum centre-to-centre distance $M_{max} = M_{min} + 116$

*last updated 10/18



TRANSPARENT LEVEL GAUGES

Type TA 120



TA 120

PN 250

120 bar

323 °C

Saturated Steam

Nominal pressure:

PN 250, 120 bar
323 °C saturated steam
with gauge valve DVK 2
Construction to KLINGER
material code FS/H

Gauge glass:

Klinger Transparent glass TA 28
Material Borosilicate
Mica shield TA 28
Illuminator IP 65

Connection gauge body – gauge cock

Rotatable (360°)

Connecting piece with flanges. Seal between gauge and connecting piece: joint ring.

Connection construction

End connection with DVK 2 gauge valves (see illustration). Safety ball in the upper and lower shut-off fitting.

Vessel connection by flanges or male threads available to all recognized standards.

Weight: Gauge valve set with DN 25 flanges approx 44 kg.

Torque for body bolts 300 Nm, cold 270 Nm under working conditions.

For gauge body and gauge valve part lists, dimensions of glasses and material specifications see pages 12 and 39.

Suggested order specification Transparent level gauge PN 250

KLINGER material code FS/H
Gauge glass Borosilicate
thermally prestressed
Connection gauge body – shut-off fittings rotatable
Shut-off fittings gauge valves with safety balls

Ordering example:

**TA 120-DVK 2, VIII, FS/H
DN 25 / PN 250
M= 508 mm**

TA 120-DVK 2

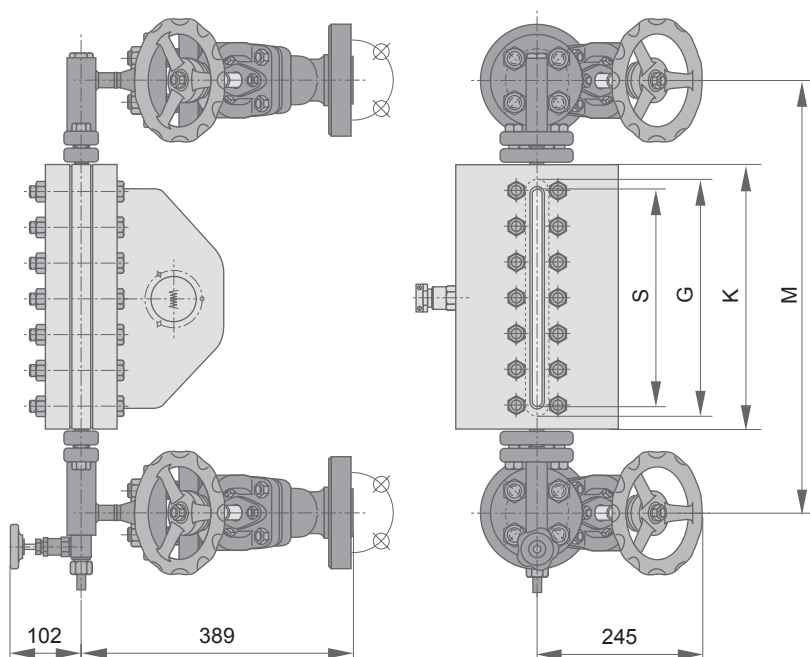

Overall and connection dimensions (mm)

Gauge size	Centre-to-centre distance M min	Body length K	Sight length S	Glass length G	Approx. weight of gauge (kg)
III	353	220	145	163	30,00
IV	378	245	170	188	33,00
V	408	275	200	218	38,00
VI	438	305	230	248	44,00
VII	468	335	260	278	52,00
VIII	508	375	300	318	62,50
IX	528	395	320	338	69,50

The maximum centre-to-centre distance $M_{max}=M_{min}+116$, larger centre-to-centre distances can be achieved by the use of mounting plates.

*last updated 10/18



ALPHA GROUP
Steam & Fluid Control Solution

139 Soi Nuanchan 34, Nuanchan Road, Nuanchan, Buengkum, Bangkok 10230
Tel : 02 792 9333 Fax : 02 946 1755-6 Email : sales@alphagroup.co.th www.alphagroup.co.th